



Lösung 1

$$1. y = c \wedge (a \not\leftrightarrow b) \wedge \bar{d} = c(\bar{a}b \vee a\bar{b})\bar{d} = \bar{c}a\bar{b}\bar{d} \vee c\bar{a}b\bar{d}$$

$$\text{NAND: } y = \overline{\overline{\bar{c}a\bar{b}\bar{d}} \vee \overline{c\bar{a}b\bar{d}}} = \overline{\overline{\bar{c}a\bar{b}\bar{d}} \wedge \overline{c\bar{a}b\bar{d}}} \\ = \text{NAND}_2(\text{NAND}_4(c, \bar{a}, b, \bar{d}), \text{NAND}_4(c, a, \bar{b}, \bar{d}))$$

$$\text{NOR: } \bar{y} = \overline{\overline{\bar{c}a\bar{b}\bar{d}} \vee \overline{c\bar{a}b\bar{d}}} = \overline{\overline{\bar{c}a\bar{b}\bar{d}} \wedge \overline{c\bar{a}b\bar{d}}} \\ = \text{NOR}_2(\text{NOR}_4(\bar{c}, a, \bar{b}, d), \text{NOR}_4(\bar{c}, a, b, d)) \\ y = \bar{y} \nabla \bar{y} \quad \text{oder: } y = \text{NOR}_2(\bar{y}, \bar{y})$$

$$2. y = (c \leftrightarrow b)\bar{a} = \overline{(cb \vee \bar{c}\bar{b})} \wedge a = \overline{cba \vee \bar{c}\bar{b}a} = (\bar{c} \vee \bar{b} \vee \bar{a})(c \vee b \vee \bar{a})$$

$$\text{NAND: } \bar{y} = \overline{\overline{cba \vee \bar{c}\bar{b}a}} = \overline{\overline{cba} \wedge \overline{\bar{c}\bar{b}a}} \\ = \text{NAND}_2(\text{NAND}_3(c, b, a), \text{NAND}_3(\bar{c}, \bar{b}, a)) \\ y = \bar{y} \bar{\wedge} \bar{y} \quad \text{oder: } y = \text{NAND}_2(\bar{y}, \bar{y})$$

$$\text{NOR: } y = \overline{\overline{(\bar{c} \vee \bar{b} \vee \bar{a})(c \vee b \vee \bar{a})}} = \overline{\overline{(\bar{c} \vee \bar{b} \vee \bar{a})} \vee \overline{(c \vee b \vee \bar{a})}} \\ = \text{NOR}_2(\text{NOR}_3(\bar{c}, \bar{b}, \bar{a}), \text{NOR}_3(c, b, \bar{a}))$$

$$3. y = (a \vee \bar{b} \wedge (b \vee \bar{c})) \wedge (\bar{a} \vee \bar{c}) = (a \vee \bar{b}b \vee \bar{b}\bar{c})(\bar{a} \vee \bar{c}) = (a \vee \bar{b}\bar{c})(\bar{a} \vee \bar{c}) \\ = a\bar{a} \vee a\bar{c} \vee \bar{b}\bar{c}\bar{a} \vee \bar{b}\bar{c}\bar{c} = a\bar{c} \vee \bar{c}\bar{b}\bar{a} \vee \bar{b}\bar{c} = a\bar{c} \vee \bar{b}\bar{c}$$

$$\text{NAND: } y = \overline{\overline{a\bar{c} \vee \bar{b}\bar{c}}} = \overline{\overline{a\bar{c}} \wedge \overline{\bar{b}\bar{c}}} \\ = \text{NAND}_2(\text{NAND}_2(a, \bar{c}), \text{NAND}_2(\bar{b}, \bar{c}))$$

$$\text{NOR: } \bar{y} = \overline{\overline{a\bar{c} \vee \bar{b}\bar{c}}} = \overline{\overline{a\bar{c}} \wedge \overline{\bar{b}\bar{c}}}$$

$$= \text{NOR}_2(\text{NOR}_2(\bar{a}, c), \text{NOR}_2(b, c))$$

$$y = \bar{y} \nabla \bar{y} \quad \text{oder:} \quad y = \text{NOR}_2(\bar{y}, \bar{y})$$

4. $y = \bar{b}\bar{a} \vee cba \vee edc$

NAND: $y = \overline{\overline{\bar{b}\bar{a} \vee cba \vee edc}} = \overline{\overline{\bar{b}\bar{a}} \wedge \overline{cba} \wedge \overline{edc}}$
 $= \text{NAND}_3(\text{NAND}_2(\bar{b}, \bar{a}), \text{NAND}_3(c, b, a), \text{NAND}_3(e, d, c))$

NOR: $\bar{y} = \overline{\bar{b}\bar{a} \vee cba \vee edc} = \overline{\bar{b}\bar{a}} \wedge \overline{cba} \wedge \overline{edc}$
 $= \text{NOR}_3(\text{NOR}_2(b, a), \text{NOR}_3(\bar{c}, \bar{b}, \bar{a}), \text{NOR}_3(e, d, c))$
 $y = \bar{y} \nabla \bar{y} \quad \text{oder:} \quad y = \text{NOR}_2(\bar{y}, \bar{y})$

Lösung 2

1. Realisierung von $g_1(c, b, a)$ mit NAND-Gattern mit zwei Eingängen ($\bar{\wedge}$ -Operator):

$$g_1(c, b, a) = \overline{\overline{((\bar{c} \vee \bar{b}) \wedge (\bar{b} \vee \bar{a})) \vee (c \wedge \bar{a})}}$$

$$= \overline{((\bar{c} \vee \bar{b}) \wedge (\bar{b} \vee \bar{a})) \vee (c \wedge \bar{a})}$$

$$= ((\bar{c} \vee \bar{b}) \bar{\wedge} (\bar{b} \vee \bar{a})) \bar{\wedge} (c \bar{\wedge} \bar{a})$$

$$= ((c \bar{\wedge} b) \bar{\wedge} (b \bar{\wedge} a)) \bar{\wedge} (c \bar{\wedge} \bar{a}) \quad (\bar{a} = a \bar{\wedge} a)$$

Schaltbild:

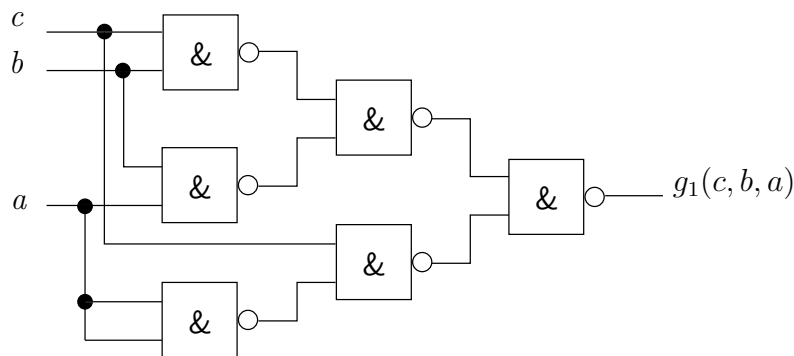

2. Realisierung von $g_2(c, b, a)$ mit NOR-Gattern mit zwei Eingängen ($\bar{\vee}$ -Operator):

$$g_2(x_1, x_2, x_3) = \overline{x_1 \vee x_2 \vee x_3} = \overline{(x_1 \bar{\vee} x_2)} \bar{\vee} x_3$$

Lösung 4

1. CMOS-Transistor-Schaltbild von $f(c, b, a)$:

$$f(c, b, a) = \overline{c(b \vee a)} = c \overline{(b \vee a)} = c \overline{(b \overline{a})}$$

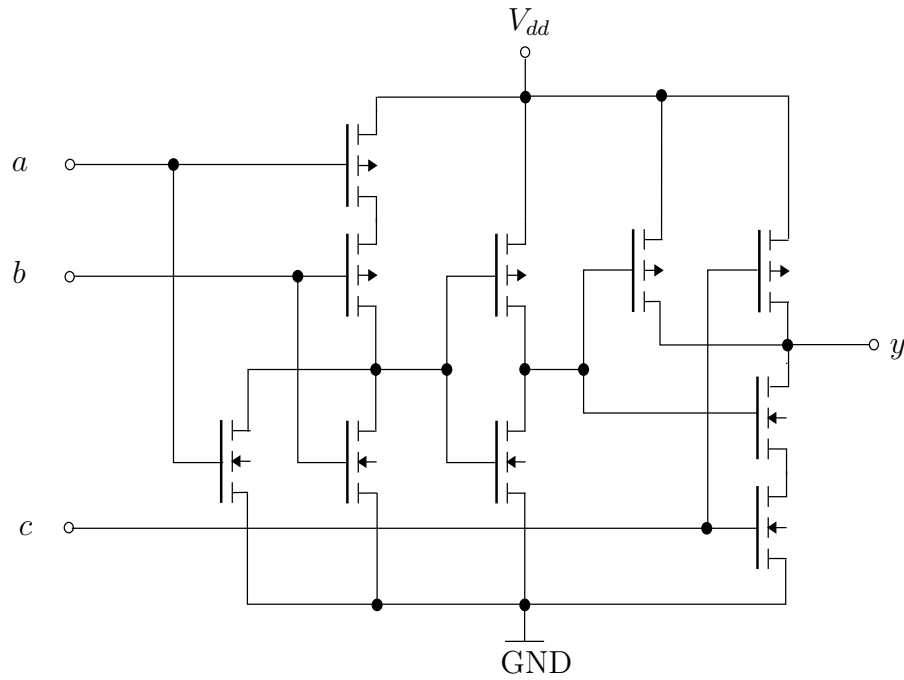

2. Transistorschaltbild:

